

# Digital Timing Light



# Table of Contents

<u>Paragraph</u>	<u>Page No.</u>
<b>SAFETY GUIDELINES</b> .....	<b>1</b>
<b>VEHICLE SERVICE MANUALS</b> .....	<b>2</b>
<b>GENERAL INFORMATION</b> .....	<b>3</b>
ENGINE TIMING AND TUNE-UPS.....	3
ABOUT THE TIMING LIGHT .....	3
<b>USING YOUR TIMING LIGHT</b> .....	<b>5</b>
BEFORE YOU BEGIN .....	5
ENGINE PREPARATION BEFORE TIMING .....	5
TIMING LIGHT CONNECTION.....	6
INITIAL (BASE) TIMING CHECK.....	6
TIMING ADJUSTMENT .....	7
ADVANCE TIMING CONTROL CHECKS .....	7
<b>TROUBLESHOOTING</b> .....	<b>10</b>
<b>CARE AND MAINTENANCE</b> .....	<b>11</b>
CLEANING THE INDUCTIVE PICKUP.....	11
REPLACING THE INDUCTIVE PICKUP LEADS .....	11
<b>WARRANTY AND SERVICE</b> .....	<b>13</b>
LIMITED ONE YEAR WARRANTY.....	13
SERVICE PROCEDURES.....	13

# Safety Guidelines

## SAFETY EQUIPMENT

### Fire Extinguisher

Keep a fire extinguisher suitable for gasoline/chemical/electrical fires on hand whenever working on a vehicle.

### Fireproof Container

Store rags and flammable liquids only in fireproof containers. Allow soaked rags to dry thoroughly in open air before discarding.

### Safety Goggles

Wear safety goggles when working on a vehicle to protect your eyes from battery acid, gasoline, and airborne dust and dirt from moving engine parts.

## LOOSE CLOTHING AND LONG HAIR (MOVING PARTS)

Be very careful not to get your hands, hair or clothes near any moving parts such as fan blades, belts and pulleys or throttle and transmission linkages. **DO NOT** wear loose clothing or jewelry when working on a vehicle.

## VENTILATION

**ALWAYS** operate vehicle in a well-ventilated area. If vehicle is in an enclosed area, exhaust should be routed directly to the outside using a leakproof exhaust hose.

## SETTING THE BRAKE

Make sure that your car is in Park or Neutral, and that the parking brake is firmly set.

## HOT SURFACES

Avoid contact with hot surfaces such as exhaust manifolds, pipes, mufflers, radiator and hoses. Never remove the radiator cap while the engine is hot. Escaping coolant under pressure can cause serious burns.

## SMOKING AND OPEN FLAMES

Never smoke while working on your car. Gasoline vapor is highly flammable, and the gas formed in a charging battery is explosive.

## BATTERY

Do not lay tools or equipment on the battery. Accidentally grounding the battery's positive (+) terminal can shock or burn you and damage wiring, the battery or your tools and testers. Be careful of contact with battery acid. It can burn holes in your clothing and burn your skin or eyes.

When operating any test instrument from an external battery, connect a jumper wire between the negative terminal of the external battery and ground on the vehicle under test. When working in a garage or other enclosed area, the external battery should be located at least 18 inches above the floor to minimize the possibility of igniting gasoline vapors.

## HIGH VOLTAGE

High voltage is present in the ignition coil, distributor cap, ignition wires and spark plugs. When handling ignition wires while the engine is running, use insulated pliers to avoid a shock.

## JACK

The jack supplied with the vehicle should be used only for changing wheels. Never crawl under car or run engine while vehicle is on a jack.

# Vehicle Service Manuals

Contact your local car dealership, auto parts store, bookstore or public library for availability of service manuals for your vehicle. The following companies publish valuable repair manuals. Write to them for availability and prices. Be sure to include the make, model and year of your vehicle.

## FACTORY SOURCES

### **Ford/General Motors Service Manuals**

#### **Helm Inc.**

14310 Hamilton Ave.  
Highland Park, Michigan 48203  
Telephone (800) 782-4356

## NON-FACTORY SOURCES

### **Chek-Chart Publications**

1515 Grandview Parkway  
Sturtevant, Wisconsin 53117  
Telephone (800) 662-6277

### **Haynes Publications**

861 Lawrence Dr.  
Newbury Park, California 91320  
Telephone (805) 498-6703

### **Mitchell International**

9889 Willow Creek Rd.  
P. O. Box 26260  
San Diego, California 92196-0260  
Telephone (619) 578-6550

### **Motor Publications**

5600 Crooks Rd.  
Troy, Michigan 48098  
Telephone (800) 426-6867

## **IMPORTANT!**

Timing procedures vary from vehicle to vehicle. **ALWAYS** refer to the Vehicle Emission Label or service manual for your vehicle to obtain the proper timing procedures, specifications, and location of timing marks. **OBSERVE ALL SAFETY PRECAUTIONS WHENEVER WORKING ON A VEHICLE.**

## ENGINE TIMING AND TUNE-UPS

Proper ignition timing is critical in order to achieve peak engine performance and to ensure maximum fuel economy. An ignition system timing check is critical during any tune-up procedure. Your timing light provides a simple and efficient means of checking your vehicle's ignition timing, and provides the additional ability to check the operation of your vehicle's mechanical or vacuum advance timing controls.

You may also need tools and equipment to check breaker point dwell (for conventional ignition systems) or to apply vacuum to the vacuum advance diaphragm on the distributor during advance checks. Your supplier offers a wide range of tools and equipment necessary to perform these tasks.

With reference to today's "self-tuning" vehicles, the meaning of the term "tune-up" has changed significantly. A tune-up consists essentially of checking engine operation with Original Equipment Manufacturer's specifications. Adjustments are made and parts are replaced **ONLY** if engine performance is not within specifications.

## ABOUT THE TIMING LIGHT

Your timing light is designed for use on all 12-volt *negative* ground vehicles equipped with conventional breaker point and electronic ignition systems (*not compatible with DIS systems*).

### For 6-Volt Electrical Systems

- Requires a separate 12-volt auto-motive battery.

Your timing light may be used on vehicles with 6-volt electrical systems by using the following connection procedure:

1. Connect the **RED** battery clip to the positive (+) terminal of the 12-volt battery.
2. Connect the **BLACK** battery clip to the negative (-) terminal of the 12-volt battery.
3. Using a length of 18AWG jumper wire, ground the negative (-) terminal of the 12-volt battery to a known-good ground on the vehicle under test.
4. Perform remaining connection and test procedures as specified in the appropriate sections of this manual.

## Timing Light Controls

Controls for the timing light are shown in Figure 1.

1. **Xenon Bulb** — Used to illuminate timing marks for checking timing.
2. **Swiveling Head** — Contains the xenon bulb. Rotates over approximately 70° to allow for easy illumination of timing marks in hard to reach locations.
3. **Control Panel** — Contains the controls necessary to operate the timing light.
4. **Inductive Pickup Leads** — Detachable leads assembly connects timing light to battery and ignition system:
  - **Red Battery Clip** — Connects to battery positive (+) terminal.
  - **Black Battery Clip** — Connects to battery negative (-) terminal or bare metal chassis ground.
  - **Inductive Pickup Clip** — Clamps around No. 1 spark plug cable.
5. **LCD Display** — Provides a digital display of engine operating parameters including engine speed (rpm) and advance (degrees).

# General Information

Fig. 1 Timing Light Controls - General

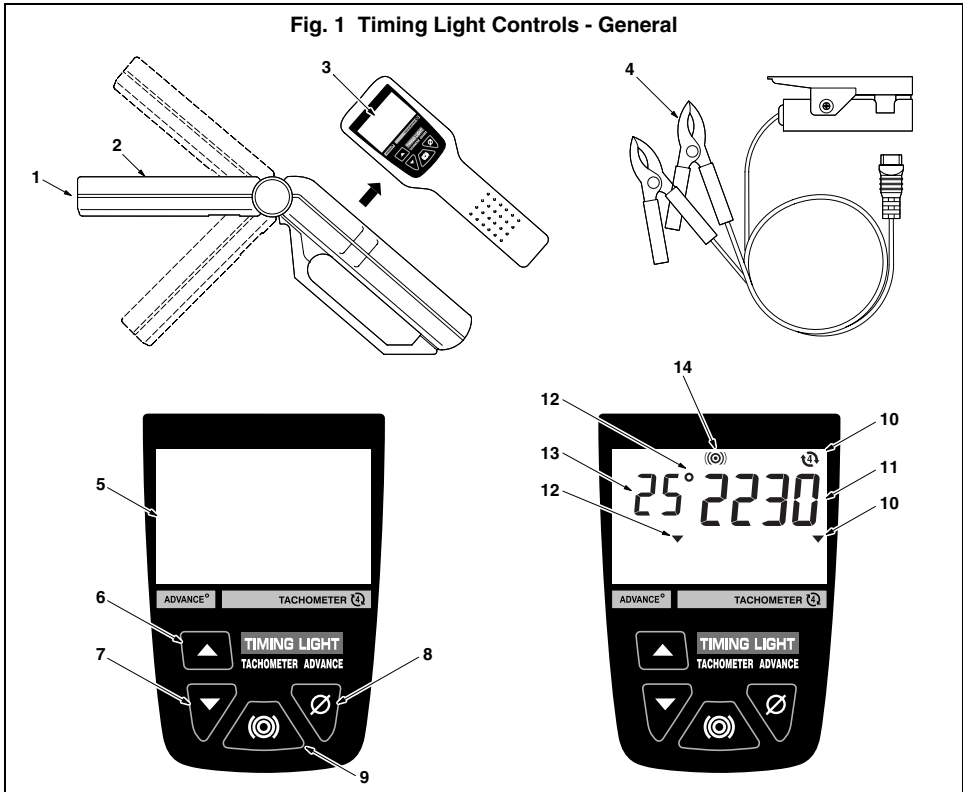

6. **Advance Increment Switch** — Increments through degrees of advance.
7. **Advance Decrement Switch** — Decrements through degrees of advance.
8. **Zeroing Switch** — Returns LCD advance display to 0 (zero) degrees.
9. **Flash Switch** — Push to turn strobe light on. Push again to turn strobe light off.
10. **Ignition Mode Indicator and Symbol**
11. **RPM Display** — Shows current engine speed in revolutions-per-minute.
12. **Advance Indicator and Symbol**
13. **Advance Display** — Shows engine timing advance in degrees.
14. **Flash Symbol** — Blinks when strobe light is operating.

# Using Your Timing Light

## BEFORE YOU BEGIN

Make a thorough check before starting any test procedure and fix any known mechanical problems before performing any test. Loose or damaged hoses, wiring, or electrical connectors are often responsible for poor engine performance.

Refer to your vehicle's service manual for proper connection of vacuum hoses, electrical wiring, and wiring harness connectors. Check the following areas:

- All fluid levels
- Spark plugs and spark plug wires
- Air cleaner
- Vacuum hoses
- Belts
- Electrical wiring
- Electrical connectors

## ENGINE PREPARATION BEFORE TIMING

Always prepare the engine for timing before performing a timing check. Refer to the Vehicle Emission Control Label or service manual for timing procedures and specifications for your vehicle. The Vehicle Emission Control Label is located under the hood in the engine compartment. The label is typically located on the underside of the hood, on a fender well or valve cover, or near the hood latch.

As a minimum, make the following preparations before timing:

1. Locate the timing mark and reference pointer. The timing mark and pointer are usually located on the crankshaft pulley or vibration damper (on the front of the engine) or on the flywheel (between the engine and transmission). Refer to Figure 2.

Make sure the timing mark and pointer are clean and clearly visible. Chalk the marks if necessary.

2. Make sure all spark plugs are in good condition and are properly gapped.
3. Start and run the engine until it reaches its normal operating temperature. **TURN THE ENGINE OFF BEFORE CONNECTING TIMING LIGHT.**

If applicable, check and adjust dwell to manufacturer's specifications.

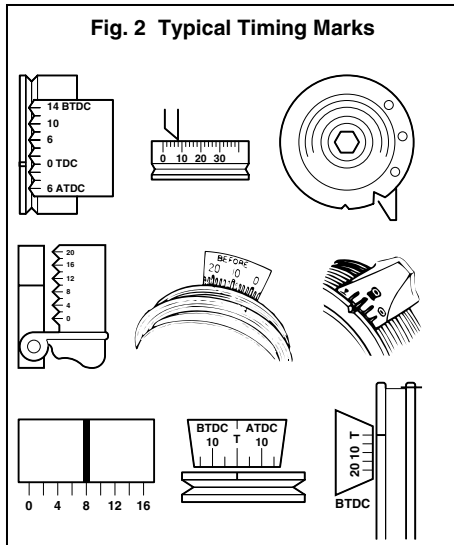

# Using Your Timing Light

## TIMING LIGHT CONNECTION

To ensure personal safety and reliable operation of the timing light, use the following procedure to connect the timing light:

### **WARNING!**

**Always keep hands, timing light, lead wires and clips away from moving engine parts and hot surfaces. DO NOT SMOKE.**

1. Turn the ignition off. **DO NOT CONNECT THE TIMING LIGHT WITH THE ENGINE RUNNING OR WITH THE IGNITION ON.**

2. Clamp the inductive pickup clip around the No. 1 spark plug wire. See Figure 3.

**DO NOT ALLOW THE INDUCTIVE PICKUP CLIP TO CONTACT THE EXHAUST MANIFOLD OR OTHER ENGINE PARTS.**

These parts become **EXTREMELY** hot while the engine is running, and will damage the inductive pickup clip.

3. Connect the battery clips to the vehicle's battery:

- Connect the **RED** battery clip to positive (+) battery terminal.
- Connect the **BLACK** battery clip to negative (-) battery terminal.

4. Connect the inductive pickup leads to the bottom of the timing light handle.

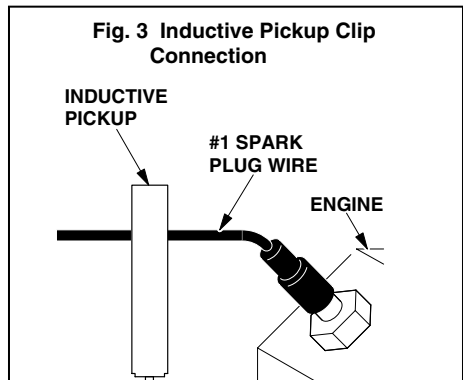

## INITIAL (BASE) TIMING CHECK

### **NOTE**

Some ignition systems require that certain components be disconnected, jumped or grounded **BEFORE** ignition timing can be checked or adjusted to specifications. If these procedures are not followed, the checked or adjusted timing will not be correct. You **MUST** consult your vehicle's service manual for the proper procedures and specifications.

1. **MAKE SURE** the timing light is properly connected as described in TIMING LIGHT CONNECTION.
2. **MAKE SURE** the engine has been properly prepared for the timing check as described in ENGINE PREPARATION BEFORE TIMING.
3. Start and run the engine until it reaches its normal operating temperature.
4. Adjust the engine's idle speed, if necessary, to conform to manufacturer's specifications:
5. **MAKE SURE** the timing light Advance Display shows 0 (zero) degrees. Press the Zeroing Switch if necessary to obtain 0 degree indication.



# Using Your Timing Light

- Adjust the timing light barrel, as needed, to adequately light the timing marks.
- Note the position of the rotating timing mark in relation to the reference pointer. See Figure 4.

- Compare the readings obtained in step 7 with the manufacturer's specifications for timing. If the readings are within the specified tolerance (typically  $\pm 2^\circ$ ), ignition timing is correct.
- If the readings are not within the manufacturer's specifications, parts replacement or timing adjustment **MAY BE** necessary.

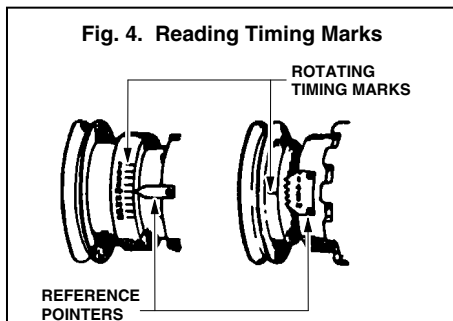

- Press the Flash Switch. The timing light will stop flashing.
- Turn the ignition off and disconnect the timing light from the engine. **BE SURE** to reconnect any vacuum hoses, etc., which were disconnected during the timing check.

## NOTE

If the timing light fails to operate or operates erratically, refer to TROUBLESHOOTING to determine the most likely cause of the problem.

## TIMING ADJUSTMENT

Refer to your vehicle's service manual for the proper procedures to adjust engine timing. **DO NOT ATTEMPT TO ADJUST ENGINE TIMING WITHOUT THE MANUFACTURER'S PROCEDURES OR SPECIFICATIONS.**

## ADVANCE TIMING CONTROL CHECKS

Advance and retard timing controls ensure that ignition occurs at the proper time during the compression stroke. These controls include:

- mechanical advance
- vacuum advance
- vacuum retard
- electronic advance
- electronic retard
- electronic advance /retard

Depending on make and model, a vehicle may be equipped with a single timing control device, or two or more devices may be used in combination.

## NOTE

Advance timing test procedures vary widely from vehicle to vehicle. The following paragraphs provide **general** test procedures for checking mechanical/centrifugal advance and vacuum advance. **ALWAYS** make sure initial timing and dwell are correct before checking advance timing. **ALWAYS** refer to the service manual for the vehicle under test to obtain the proper timing procedures and specifications. **OBSERVE ALL SAFETY PRECAUTIONS.**

# Using Your Timing Light

## Checking Mechanical/Centrifugal Timing Advance

1. **MAKE SURE** the timing light Advance Display shows 0 (zero) degrees. Press the Zeroing Switch if necessary to obtain 0 degree indication.
2. While performing an INITIAL (BASE) TIMING CHECK as previously described, slowly increase engine speed to the manufacturer's specified rpm for mechanical/centrifugal advance, and observe the rotating timing mark for change. The timing mark should appear to move smoothly, in the opposite direction of engine rotation, away from the reference pointer.

### NOTE

If timing mark movement is rough or erratic, the mechanical advance system may be de-fective. Service and repair the mechanical advance system in accordance with the man-ufacturer's instructions before continuing.

3. Press the Advance Increment and Advance Decrement switches, as necessary, until the rotating timing mark and the reference pointer realign at the initial (base) timing mark as previously recorded. Read the degrees of mechanical or centrifugal advance on the LCD display. See Figure 5.
4. Note the degrees advance shown on the LCD display, and compare this value with the manufacturer's specification for mechanical or centrifugal timing advance for the rpm specified.
  - If the position of the rotating timing mark **does not** change during the mechanical/centrifugal advance check, the mechanical weights associated with your vehicle's mechanical advance mechanism (if equipped) may be rusted or binding.
5. Repeat the test, as needed, for all engine speeds specified by the manufacturer's instructions.

Fig. 5. Advance Control Knob Operation

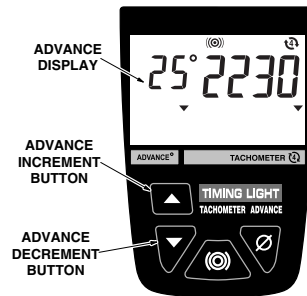

## Checking Vacuum Timing Advance

### NOTE

A vacuum pump equipped with a vacuum gauge is needed to check vacuum advance.

1. With the engine off, disconnect the vacuum hose from the distributor's vacuum advance port. Plug the vacuum hose securely.
2. Connect the vacuum pump to the distributor's vacuum port. **Do not** apply vacuum at this time.
3. Start the engine and perform INITIAL (BASE) TIMING CHECK as previously described. Record the degree(s) of initial (base) timing.
4. Using the vacuum pump, apply the manufacturer's specified amount of vacuum to the distributor's vacuum port.

# Using Your Timing Light

5. Aim the timing light at the timing marks and press the Advance Increment and Advance Decrement switches, as necessary, until the timing marks are realigned to the initial (base) timing mark as recorded in step 3.
6. The difference between the reading obtained in step 3 {initial (base) timing} and the value obtained in step 5 is the vehicle's vacuum advance. Compare this value with the manufacturer's specifications for vacuum advance.
7. Repeat the test, as needed, for each amount of vacuum specified by the manufacturer's instructions.
8. Turn off the ignition and disconnect the timing light and vacuum pump from the engine. Unplug and reconnect the vacuum hose to the distributor's vacuum port.

## **Checking Vacuum/Electronic Retard and Electronic Advance**

The procedures for checking vacuum/electronic retard and electronic advance vary between vehicles and manufacturers. Refer to your vehicle's service manual for specifications and procedures.

A vacuum pump equipped with a vacuum gauge is required to check vacuum retard.

# Troubleshooting

If the timing light fails to operate or operates erratically, make the following checks:

1. Make sure the battery clips are firmly connected to the battery terminals.
2. Make sure the battery clip polarity is correct (red battery clip is connected to the positive (+) battery terminal, black battery clip is connected to the negative (-) battery terminal).
3. Make sure the upper and lower ferrite cores of the inductive pickup clip are clean. If necessary, clean the inductive pickup clip as described in MAINTENANCE.
4. Make sure the inductive pickup clip is properly connected to the No. 1 spark plug cable.
5. Make sure the No. 1 spark plug is working properly:
  - Connect the inductive pickup clip to another spark plug cable, and press the Flash switch.
  - If the timing light flashes, service the No. 1 spark plug before continuing.

## NOTE

Low spark plug voltage or a faulty spark plug wire may cause the timing light to operate erratically. Try moving the inductive pickup clip to a new location on the plug wire to improve operation.

Some ignition systems and/or specialty spark plug wires (solid core wires, racing wires, off-road wires) radiate above normal Electro-Magnetic Interference (EMI) and Radio Frequency Interference (RFI) which can cause improper operation of testing equipment. Contact the manufacturers of these parts for instructions on how to use an inductive pickup with their systems.

## CLEANING THE INDUCTIVE PICKUP CLIP

Dirt or grease on the inside surfaces of the inductive pickup clip can result in erratic flashing or poor operation of the timing light. Periodically clean the contact surfaces inside the inductive pickup clip by wiping with a soft cloth. See Figure 6.

## REPLACING THE INDUCTIVE PICKUP LEADS

The timing light is equipped with detachable leads which can be disconnected from the timing light for easy storage after use. If the test leads or clips become damaged, a replacement set can be obtained from your dealer or directly from the service center.

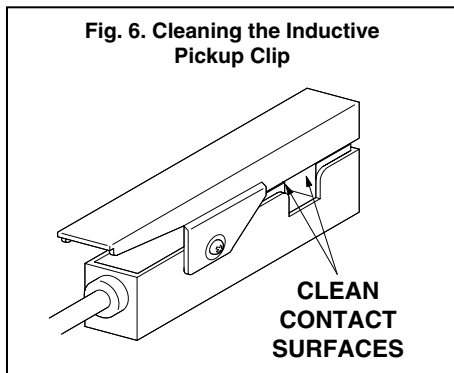



# *Warranty and Service*

## **LIMITED ONE YEAR WARRANTY**

The Manufacturer warrants to the original purchaser that this unit is free of defects in materials and workmanship under normal use and maintenance for a period of one (1) year from the date of original purchase. If the unit fails within the one (1) year period, it will be repaired or replaced, at the Manufacturer's option, at no charge, when returned prepaid to the Service Center with Proof of Purchase. The sales receipt may be used for this purpose. All replacement parts, whether new or re-manufactured, assume as their warranty period only the remaining time of this warranty. This warranty does not apply to damage caused by improper use, accident, abuse, improper voltage, service, fire, flood, lightning, or other acts of God, or if the product was altered or repaired by anyone other than the Manufacturer's Service. The Manufacturer, under no circumstances shall be liable for any consequential damages for breach of any written warranty of this unit. This warranty gives you specific legal rights, and you may also have rights which vary from state to state. This manual is copyrighted with all rights reserved. No portion of this document may be copied or reproduced by any means without the express written permission of the Manufacturer. **THIS WARRANTY IS NOT TRANSFERABLE.** For service, send via U.P.S. (if possible) prepaid to Manufacturer. Allow 3-4 weeks for service/repair.

## **SERVICE PROCEDURES**

If you have any questions, please contact your local store, distributor or the Service Center.

USA & Canada:

(800) 544-4124 (6:00am-6:00pm, 7 days a week PST)

All others:

(714) 241-6802 (6:00am-6:00pm, 7 days a week PST)

FAX:

(714) 432-3979 (24 hr.)



17352 Von Karman Avenue  
Irvine, CA 92614

MRP #93-0149 Rev. D  
Copyright © 2012 IEC. All Rights Reserved.

